

Treasure Hunt

- What makes Ezekiel, rather than Jeremiah or Daniel, an appropriate namesake for the Lord Jesus?
- The title “son of man” would be true of any human. What is significant about God’s singling out Ezekiel?
- Why does God use this title, once, to address Daniel?
- What forms the backbone of the book of Ezekiel?
- What are the themes of each of Ezekiel’s three visions?
- What episodes in our Lord’s life show his zeal for the temple?
- How should the examples of Ezekiel, Daniel, and our Lord motivate us?

Instances of “Son of Man”

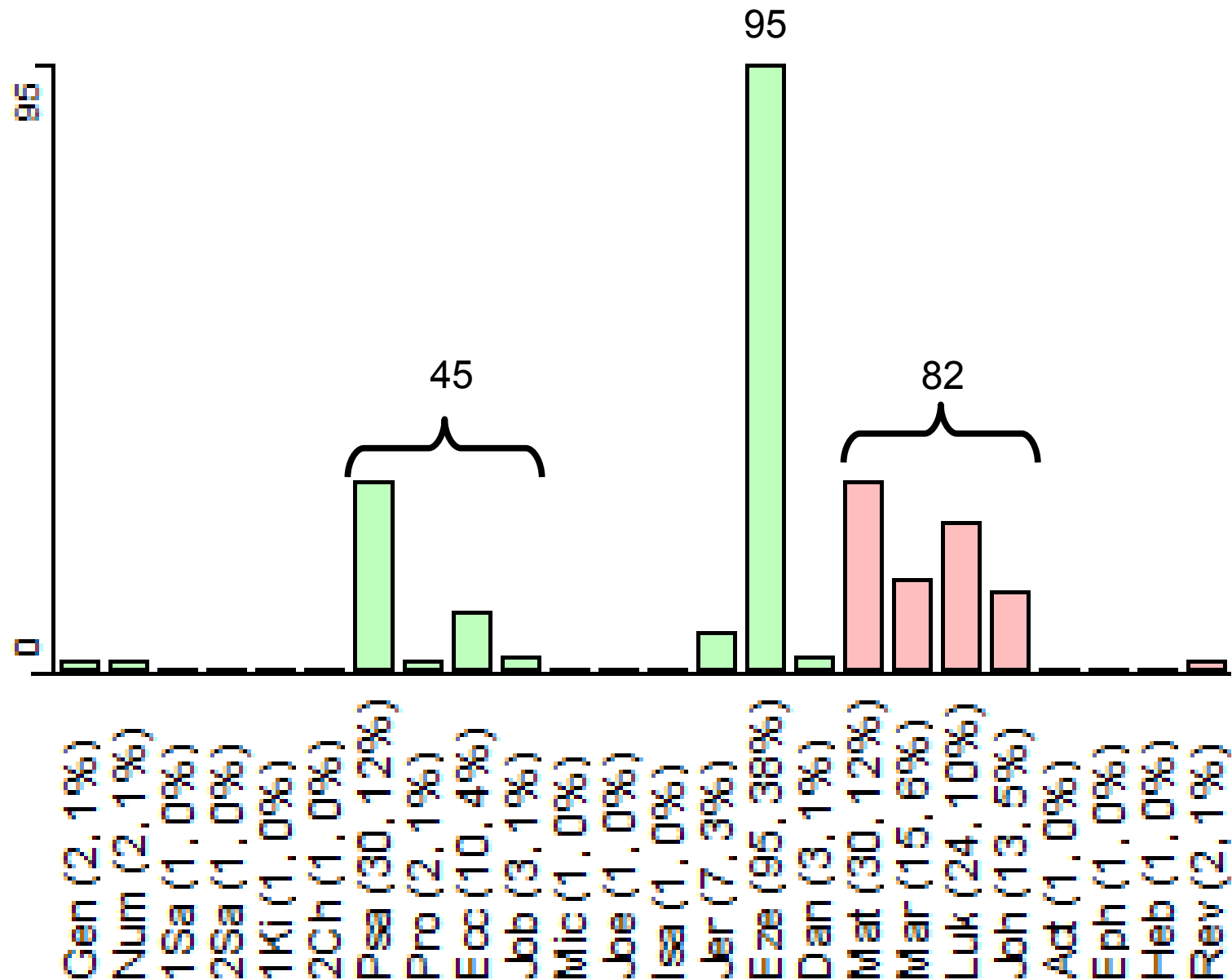

Development of the “Son of Man” Title

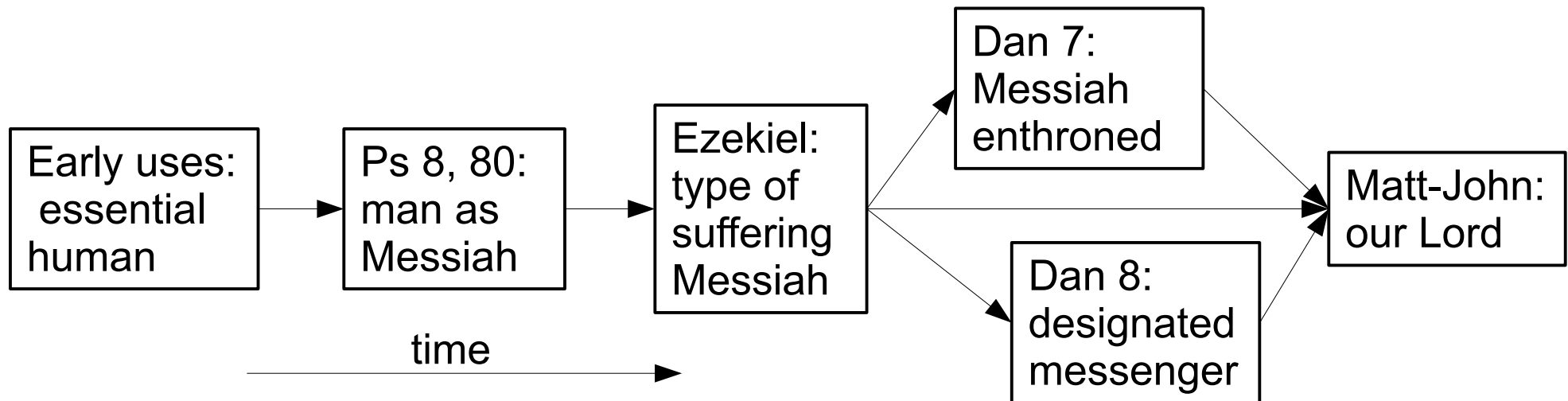

Similarities between Ezekiel and our Lord

- Similar calls to ministry
- Among a captive people
- Divinely designated human
- Concern for a pure sanctuary
- Teaching in parables
- Roles as sin-bearers

A Prophet Among the Captives

Prophets during the Babylonian captivity: Jeremiah, Ezekiel, Daniel

| | Location | Audience |
|----------------|-----------|----------|
| Jeremiah | Jerusalem | Jews |
| Ezekiel | Babylon | |
| Daniel | | Gentiles |

Eze 3:4 And he said unto me, Son of man, go, get thee unto the house of Israel, and speak with my words unto them. 5 For thou *art* not sent to a people of a strange speech and of an hard language, *but* to the house of Israel; 6 Not to many people of a strange speech and of an hard language, whose words thou canst not understand. Surely, had I sent thee to them, they would have hearkened unto thee. 7 But the house of Israel will not hearken unto thee; for they will not hearken unto me: for all the house of Israel *are* impudent and hardhearted.

As “son of man” he can be “touched with the feeling of our infirmities” (Heb 4:15).

Divinely Designated Human

Title in Ezekiel is always vocative: “You, Son of Man, I’m talking to you...” E.g.,

Eze 2:1 And he said unto me, **Son of man**, stand upon thy feet, and I will speak unto thee.

Eze 2:3 And he said unto me, **Son of man**, I send thee to the children of Israel,

Eze 2:6 And thou, **son of man**, be not afraid of them,

Eze 2:8 But thou, **son of man**, hear what I say unto thee;

Only other instance of the vocative in the Greek Bible is Daniel:

Dan 8:16 And I heard a man's voice between *the banks of* Ulai, which called, and said, Gabriel, make this *man* to understand the vision. 17 So he came near where I stood: and when he came, I was afraid, and fell upon my face: but he said unto me,

Understand, O son of man: for at the time of the end *shall be* the vision.

8:17 is 550 BC (Dan 8:1); Ezekiel’s last sermon is 572 BC (Ezek 40:1)

Ezekiel and the Sanctuary

Prophecies of
Judgment
3:16-7:27

Prophecies of
Restoration
ch. 34-39

1-3 (1:1 I saw
visions of God)
The Glory of
God

8-11 (8:3 the spirit lifted me up
... and brought me in the
visions of God to Jerusalem)
The Glory Leaves the Old
Temple

Prophecies of
Judgment
ch. 12-33

40-48 (40:2 In the
visions of God
brought he me into
the land of Israel)
The Glory Returns
to the New Temple

1-3, The Glory Comes to Babylon

Eze 1:4 And I looked, and, behold, a whirlwind came out of the north, a great cloud, and a fire infolding itself, and a brightness *was* about it, and out of the midst thereof as the colour of amber, out of the midst of the fire. 5 Also out of the midst thereof *came* **the likeness of four living creatures**. ... 22 And **the likeness of the firmament** upon the heads of the living creature *was* as the colour of the terrible crystal, stretched forth over their heads above. ... 25 And there was a voice from the firmament that *was* over their heads, when they stood, *and* had let down their wings. 26 And above the firmament that *was* over their heads **was the likeness of a throne**, as the appearance of a sapphire stone: and upon the likeness of the throne **was the likeness as the appearance of a man** above upon it. ... 28 As the appearance of the bow that is in the cloud in the day of rain, so *was* the appearance of the brightness round about. **This was the appearance of the likeness of the glory of the LORD.**

Eze 3:12 Then the spirit took me up, and I heard behind me a voice of a great rushing, *saying*, Blessed *be* the glory of the LORD from his place. → “The glory of the Lord is more blessed than its place”

ch. 8, the Motive for the Departure

Eze 8:5 behold northward at the **gate of the altar** this **image of jealousy** in the entry. 6 He said furthermore unto me, Son of man, seest thou what they do? *even* the great abominations that the house of Israel committeth here, that I should go far off from my sanctuary? but turn thee yet again, **and thou shalt see greater abominations.** ...

10 So I went in and saw; and behold **every form of creeping things, and abominable beasts, and all the idols** of the house of Israel, pourtrayed **upon the wall** round about. ... 13 He said also unto me, Turn thee yet again, **and thou shalt see greater abominations** that they do.

14 Then he brought me to **the door of the gate of the LORD'S house which was toward the north;** and, behold, there sat **women weeping for Tammuz.** 15 Then said he unto me, Hast thou seen *this*, O son of man? turn thee yet again, **and thou shalt see greater abominations** than these.

16 And he brought me into **the inner court** of the LORD'S house, and, behold, **at the door of the temple** of the LORD, between the porch and the altar, *were* about five and twenty men, with their backs toward the temple of the LORD, and their faces toward the east; and **they worshipped the sun** toward the east. 17 Then he said unto me, **Hast thou seen this, O son of man?**

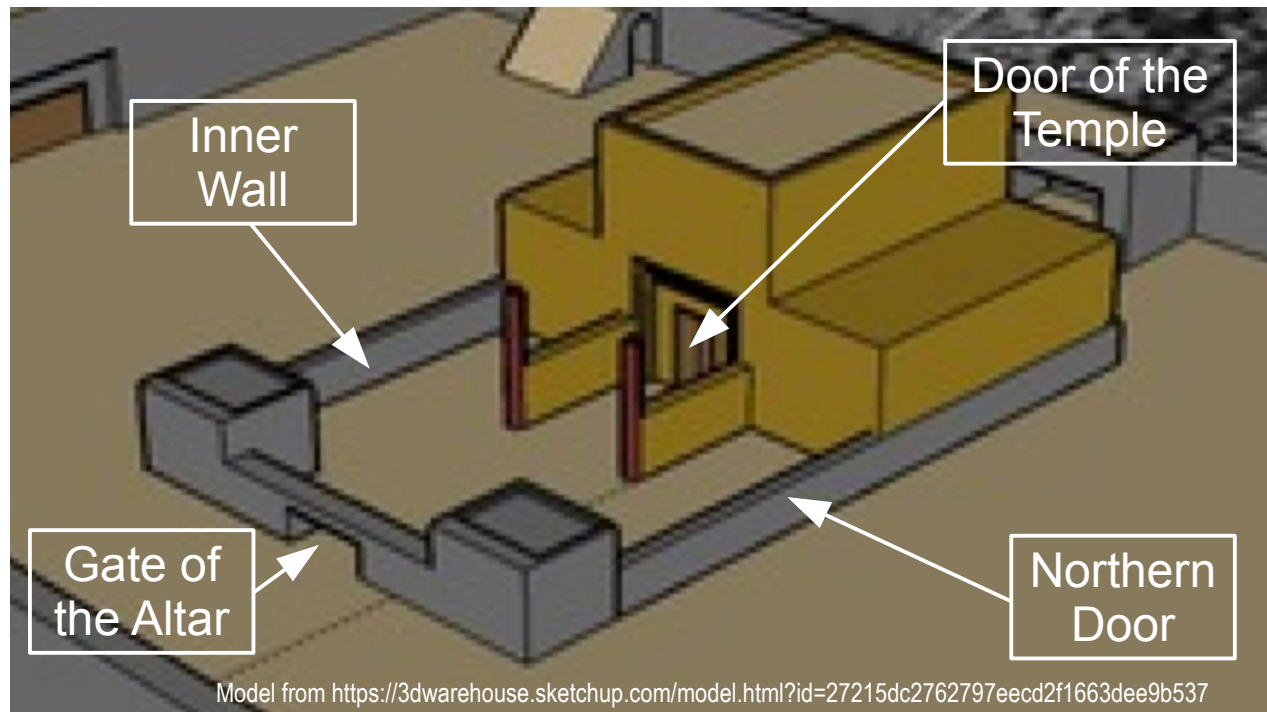

ch. 10-11, The Glory Departs

Eze 10:4 Then the glory of the LORD went up **from the cherub** [of the ark in the Holy of Holies},

and stood over the **threshold** of the house; ... 18 Then the glory of the LORD departed **from off the threshold** of the house,

and stood **over the cherubims**. 19 And the cherubims lifted up their wings, and mounted up from the earth in my sight: ... and *every one* stood at **the door of the east gate** of the LORD'S house; and the glory of the God of Israel *was* over them above.

Eze 11:22 Then did the cherubims lift up their wings, ... and the glory of the God of Israel *was* over them above. 23 And the glory of the LORD went up from the midst of the city, and stood **upon the mountain** which *is* on the east side of the city [the Mount of Olives].

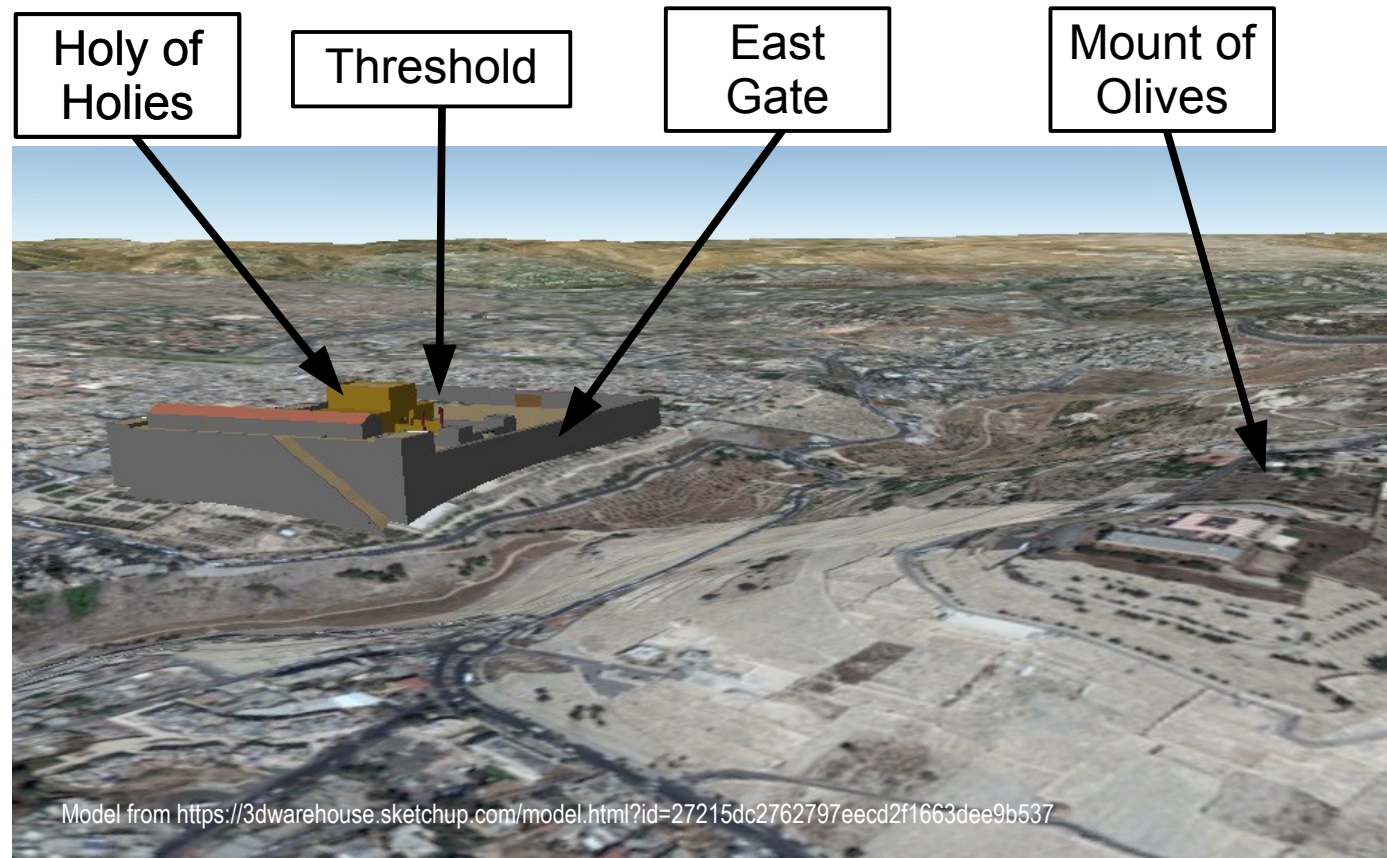

ch. 40-48, the New Sanctuary

Eze 43:10 Thou son of man, shew the house to the house of Israel, that they may be ashamed of their iniquities: and let them measure the pattern. 11 And if they be ashamed of all that they have done, shew them the form of the house, and the fashion thereof, and the goings out thereof, and the comings in thereof, and all the forms thereof, and all the ordinances thereof, and all the forms thereof, and all the laws thereof: and write *it* in their sight, that they may keep the whole form thereof, and all the ordinances thereof, and do them.

Our Lord's Zeal for God's Sanctuary

Start of ministry:

Joh 2:14 [Jesus] found in the temple those that sold oxen and sheep and doves, and the changers of money sitting: 15 And when he had made a scourge of small cords, he drove them all out of the temple, and the sheep, and the oxen; and poured out the changers' money, and overthrew the tables; 16 And said unto them that sold doves, Take these things hence; make not my Father's house an house of merchandise. 17 And his disciples remembered that it was written, The zeal of thine house hath eaten me up [Psa 69:9].

End of ministry:

Mat 21:12 And Jesus went into the temple of God, and cast out all them that sold and bought in the temple, and overthrew the tables of the moneychangers, and the seats of them that sold doves, 13 And said unto them, It is written, My house shall be called the house of prayer [Isa 56:7]; but ye have made it a den of thieves [Jer 7:11].

Matt 23: rebukes the “scribes and pharisees, hypocrites” for their corruption, then leaves the temple:

Mat 23:37 O Jerusalem, Jerusalem, *thou* that killest the prophets, and stonest them which are sent unto thee, how often would I have gathered thy children together, even as a hen gathereth her chickens under *her* wings, and ye would not! 38 Behold, your house is left unto you desolate. 39 For I say unto you, Ye shall not see me henceforth, till ye shall say, Blessed *is* he that cometh in the name of the Lord. 24:1 And Jesus went out, and departed from the temple:

Olivet Discourse warns of “the abomination of desolation, spoken of by Daniel the prophet, stand in the holy place” (24:15).

Heb 8:2 our Lord ministers in the heavenly tabernacle, “which the Lord pitched, and not man”